

BEKO

*installation, operation &
food storage instructions*

GNE114610APX



get the **best** from your new refrigerator

Please read this manual first!

Dear Customer,

We hope that your product, which has been produced in modern plants and checked under the most meticulous quality control procedures, will provide you with years of good service.

For this, we recommend you to carefully read the entire manual of your product before using it and keep it at hand for future reference.



This manual

- Will help you use your appliance quickly and safely.
- Read the manual before installing and operating your product.
- Follow the instructions, especially those for safety.
- Keep the manual in an easily accessible place as you may need it later.
- Besides, read also the other documents provided with your product.

Please note that this manual may be valid for other models as well.

Symbols and their descriptions

This instruction manual contains the following symbols:

-  Important information or useful usage tips.
-  Warning against dangerous conditions for life and property.
-  Warning against electric voltage.



This product is supplied with the selective sorting symbol for waste electrical and electronic equipment (WEEE).

This means that this product must be handled pursuant to European Directive 2002/96/EC in order to be recycled or dismantled to minimise its impact on the environment. For further information, please contact your local or regional authorities.

Electronic products not included in the selective sorting process are potentially dangerous for the environment and human health due to the presence of hazardous substances.

CONTENTS

<u>1 Your refrigerator</u>	<u>3</u>	<u>5 Using your refrigerator</u>	<u>12</u>
		Indicator Panel.....	12
		Door Open Alarm:	14
		Egg tray.....	15
		Sliding Body Shelves	15
		Crisper	15
		Chiller compartment	15
		Rotating Middle Section	16
		Multi Zone Storage Compartment ..	16
		Blue light	16
<u>2 Warnings</u>	<u>4</u>	<u>6 Maintenance and cleaning</u>	<u>17</u>
ELECTRICAL REQUIREMENTS.....	5	Protection of plastic surfaces	17
WARNING! THIS APPLIANCE MUST BE			
EARTHED.....	5	<u>7 Recommended solutions</u>	<u>18</u>
ENERGY SAVING TIPS.....	6	<u>for the problems</u>	
<u>3 Installation</u>	<u>7</u>	<u>8 Guarantee Details</u>	<u>21</u>
Points to be considered when re-			
transporting your refrigerator	7	<u>9 How To Obtain Service</u>	<u>22</u>
Before operating your refrigerator	7		
Electric connection	8		
Disposing of the packaging	8		
Disposing of your old refrigerator	8		
Placing and Installation	9		
Floor balance adjustment	9		
Adjusting the gap between the upper			
door	10		
<u>4 Preparation</u>	<u>11</u>		

1 Your refrigerator

Congratulations on your choice of a BEKO quality Appliance which has been designed to give you service for many years.

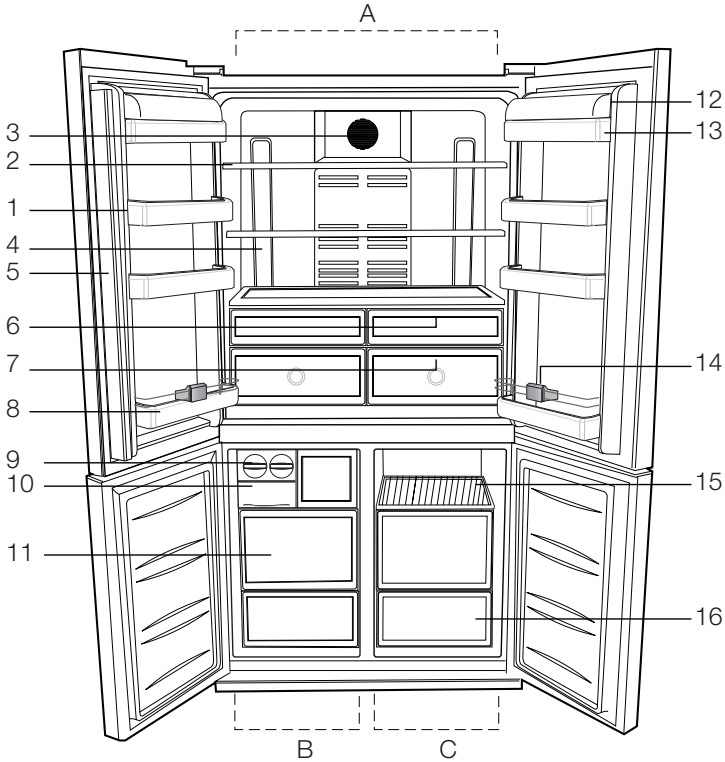

- A- Fridge compartment
- B- Freezer compartment
- C- Multi Zone

- | | |
|--|--------------------------------------|
| 1- Fridge compartment door shelves | 8- Bottle shelf |
| 2- Fridge compartment adjustable cabinet shelves | 9- Icematic |
| 3- Diffuser cover | 10- Icebox |
| 4- Illumination lens | 11- Frozen food storage compartments |
| 5- Rotating middle section | 12- Butter & Cheese shelf cover |
| 6- Chiller compartment | 13- Butter & Cheese shelf |
| 7- Crisper | 14- Bottle holder |
| | 15- Multi Zone compartment shelves |
| | 16- Multi Zone compartment |

i Figures that take place in this instruction manual are schematic and may not correspond exactly with your product. If the subject parts are not included in the product you have purchased, then it is valid for other models.

2 Warnings

- DO NOT connect your appliance to the electricity supply until all packing and transit protectors have been removed.
- Leave to stand for at least 4 hours before switching on to allow compressor oil to settle if transported horizontally.
- If you are discarding an old refrigerator with a lock or latch fitted to the door, disable the lock/latch, ensure that it is left in a safe condition to prevent the entrapment of young children.
- This fridge/freezer must only be used for its intended purpose i.e the storing and freezing of edible foodstuff.
- Do not dispose of the appliance on a fire. At **BLOMBERG**, the care and protection of our environment is an ongoing commitment. This appliance which is among the latest range introduced is particularly environment friendly. Your appliance contains non CFC / HFC natural substances in the cooling system (Called R600a) and in the insulation (Called cyclopentane) which are potentially flammable if exposed to fire. Therefore, take care not to damage, the cooling circuit / pipes of the appliance in transportation and in use. In case of damage do not expose the appliance to fire or potential ignition source and immediately ventilate the room where the appliance is situated.
- We suggest you contact your local authority for disposal information and facilities available.
- See Installation Instructions on page 9 for information on suitable location.
- To obtain the best possible performance and trouble free operation from your appliance it is very important to carefully read these instructions.
- On delivery, check to make sure that the product is not damaged and that all the parts and accessories are in perfect condition.
- Ensure that the plug remains readily accessible. Do not use multiple adapter bar or extension cable.
- Failure to observe these instructions may invalidate your right to free service during the guarantee period.
- Keep ventilation openings, in the appliance enclosure or in the built-in structure, clear of obstruction.
- Do not use mechanical devices or other means to accelerate the defrosting process, other than those recommended by the manufacturer.
- Do not damage the refrigerant circuit.
- Do not use electrical appliances inside the food storage compartments of the appliance, unless they are of the type recommended by the manufacturer.
- We suggest you keep these instructions in a safe place for easy reference.
- This appliance is not intended for use by persons (including children) with reduced physical, sensory or mental capabilities, or lack of experience and knowledge, unless they have been given supervision or instruction concerning use of the appliance by a person responsible for their safety.
- Children should be supervised to ensure that they do not play with the appliance.

ELECTRICAL REQUIREMENTS

Before you insert the plug into the wall socket make sure that the voltage and the frequency shown on the rating plate inside the appliance corresponds to your electricity supply.

Rating label is on the left hand side of fridge inner liner.

We recommend that this appliance be connected to the mains supply via a suitable switched and fused socket. The appliance must be positioned so that the plug is accessible.

Should the mains lead of the appliance become damaged or should it need replacing at any time, it must be replaced by a special purpose made mains lead which can only be obtained from a BLOMBERG Authorised Service Agent.

WARNING! THIS APPLIANCE MUST BE EARTHED

If the fitted moulded plug is not suitable for your socket, then the plug should be cut off and an appropriate plug fitted. Destroy the old plug which is cut off as a plug with bared cord could cause a shock hazard if inserted into a socket elsewhere in the house.

The moulded plug on this appliance incorporates a 13 A fuse. Should the fuse need to be replaced an ASTABEAB approved BS 1362 fuse of the same rating must be used. Do not forget to refit the fuse cover. In the event of losing the fuse cover the plug must not be used until a replacement fuse cover has been fitted. Colour of the replacement fuse cover must be the same colour as that visible on the pin face of the plug. Fuse covers are available from any good electrical store.

IMPORTANT! FITTING A DIFFERENT PLUG

As the colours of the wires in the mains lead of this appliance may not correspond with the coloured markings identifying the terminals in your plug proceed as follows: (See diagram).

1. Connect the green-yellow or green (Earth) wire to the terminal in the plug marked 'E' or with the symbol  or coloured green and yellow or green.
2. Connect the blue (Neutral) wire to the terminal in the plug marked 'N' or coloured black.
3. Connect the brown (Live) wire to the terminal in the plug marked 'L' or coloured red.

With alternative plugs a 13 A fuse must be fitted either in the plug or adaptor or in the main fuse box. If in doubt contact a qualified electrician.

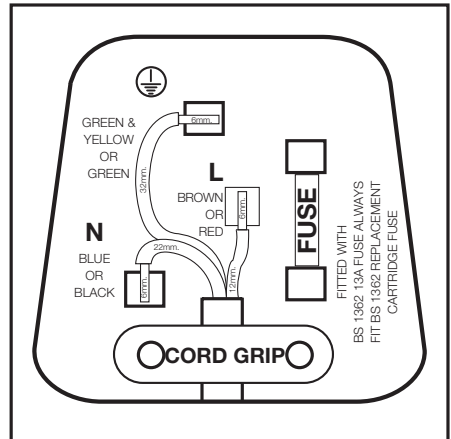

ENERGY SAVING TIPS

- 1- Ensure your appliance is installed in a well ventilated area.
- 2- Ensure the time between buying chilled/frozen food and placing them in your appliance is kept at minimum, particularly in summer. We recommend you use a cool bag or a special carrier bag to carry frozen food.
- 3- Do not leave the door (s) of your appliance open longer than necessary and ensure they are closed properly after each opening.
- 4- Defrost frozen food in the fridge compartment, so that frozen food acts as an ice pack to assist cooling in the fridge.

3 Installation

⚠ Please remember that the manufacturer shall not be held liable if the information given in the instruction manual is not observed.

- Original packaging and foam materials should be kept for future transportations or moving.

Points to be considered when re-transporting your refrigerator

1. Your refrigerator must be emptied and cleaned prior to any transportation.
2. Shelves, accessories, crisper and etc. in your refrigerator must be fastened securely by adhesive tape against any jolt before repackaging.
3. Packaging must be tied with thick tapes and strong ropes and the rules of transportation printed on the package must be followed.

Please do not forget...

Every recycled material is an indispensable source for the nature and for our national resources. If you wish to contribute to recycling the packaging materials, you can get further information from the environmental bodies or local authorities.

Before operating your refrigerator

Before starting to use your refrigerator check the following:

1. Is the interior of the refrigerator dry and can the air circulate freely in the rear of it?

2. Insert the 2 plastic wedges onto the rear ventilation as illustrated in the following figure. Unscrew the existing ones and use the screws given in the same bag of wedges. Plastic wedges will provide the required distance between your refrigerator and the wall in order to allow the air circulation.

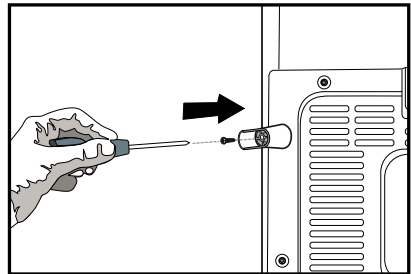
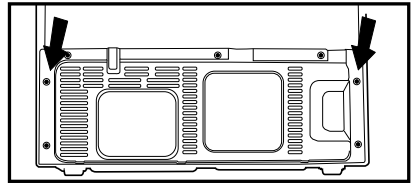

3. Clean the interior of the refrigerator as recommended in the “Maintenance and cleaning” section.
4. Plug the refrigerator into the wall outlet. When the door is open the respective interior light will come on.
5. You will hear a noise as the compressor starts up. The liquid and gases sealed within the refrigeration system may also give rise to noise, even if the compressor is not running and this is quite normal.
6. Front edges of the refrigerator may feel warm. This is normal. These areas are designed to be warm to avoid condensation.

Electric connection

Connect your refrigerator to a grounded socket which is being protected by a fuse with the appropriate capacity.

Important:

- The connection must be in compliance with national regulations.
 - The power cable plug must be easily accessible after installation.
 - Voltage and allowable fuse protection are specified in the “Technical Specifications” section.
 - The specified voltage must be equal to your mains voltage.
 - Extension cables and multiway plugs must not be used for connection.
- ⚠ A damaged power cable must be replaced by a qualified electrician.
- ⚠ The appliance must not be operated before it is repaired! There is danger of electric shock!

Disposing of the packaging

The packing materials may be dangerous for children. Keep the packing materials out of the reach of children or dispose them of by classifying them in accordance with the waste instructions. Do not dispose them of along with the normal household waste.

The packing of your refrigerator is produced from recyclable materials.

Disposing of your old refrigerator

Dispose of your old machine without giving any harm to the environment.

- You may consult your authorized dealer or waste collection center of your municipality about the disposal of your refrigerator.

Before disposing of your refrigerator, cut out the electric plug and, if there are any locks on the door, make them inoperable in order to protect children against any danger.

Placing and Installation

Caution: Never plug the refrigerator into the wall outlet during installation. Otherwise, risk of death or serious injury may arise.

If the entrance door of the room where the refrigerator will be installed is not wide enough for the refrigerator to pass through, than call the authorized service to have them remove the doors of your refrigerator and pass it sideways through the door.

1. Install your refrigerator to a place that allows ease of use.
2. Keep your refrigerator away from heat sources, humid places and direct sunlight.
3. There must be appropriate air ventilation around your refrigerator in order to achieve an efficient operation. If the refrigerator is to be placed in a recess in the wall, there must be at least 5 cm distance with the ceiling and at least 5 cm with the wall.

If the floor is covered with a carpet, your product must be elevated 2.5 cm from the floor.

4. Place your refrigerator on an even floor surface to prevent jolts.
5. Do not keep your refrigerator in ambient temperatures under 10°C.

Floor balance adjustment

If your refrigerator is unbalanced;

1- Ventilation cover is removed by unscrewing its screws as illustrated in the figure before the procedure. You can balance your refrigerator by turning the front legs of it as illustrated in the figure. The corner where the leg exists is lowered when you turn in the direction of black arrow and raised when you turn in the opposite direction. Taking help from someone to slightly lift the refrigerator will facilitate this process.

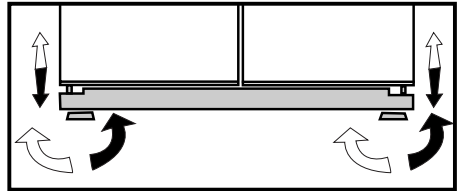

2. After the balance issue is remedied, install back the ventilation cover and fasten the screws.

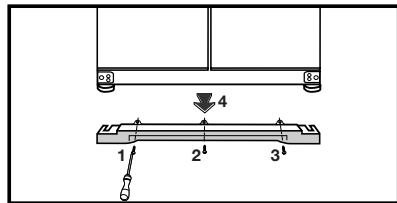

3. Remove the screws fastening the lower ventilation cover using a Phillips screwdriver.

Adjusting the gap between the upper door

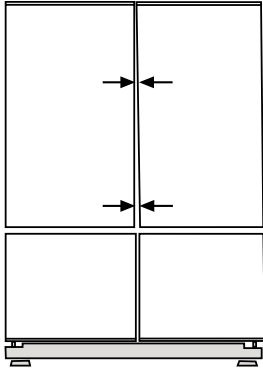

- You can adjust the gap between the fridge compartment doors as illustrated in the figures.

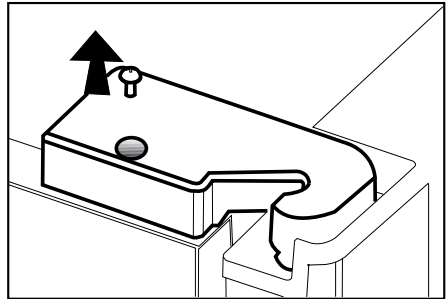

Door shelves should be empty when adjusting the door height.

- Using a screwdriver, remove the screw of upper hinge cover of the door you want to adjust.

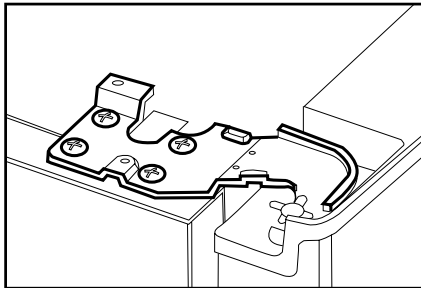

- Adjust the door as you desire by loosening the screws.

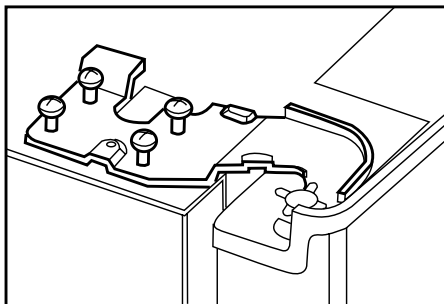
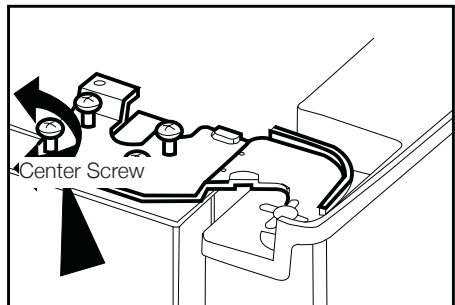

- Fix the door you have adjusted by tightening the screws without changing the position of the door.

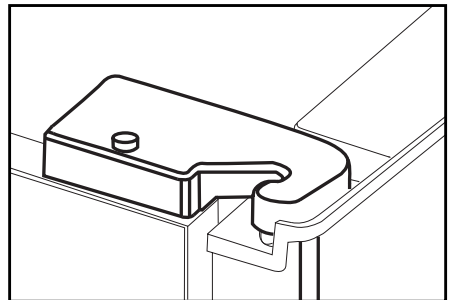

- Replace the hinge cover and fix with the screw.

4 Preparation

- i** Your refrigerator should be installed at least 30 cm away from heat sources such as hobs, ovens, central heater and stoves and at least 5 cm away from electrical ovens and should not be located under direct sunlight.
- i** The ambient temperature of the room where you install your refrigerator should at least be 10°C. Operating your refrigerator under cooler conditions than this is not recommended with regard to its efficiency.
- i** Please make sure that the interior of your refrigerator is cleaned thoroughly.
- i** If two refrigerators are to be installed side by side, there should be at least 2 cm distance between them.
- i** When you operate your refrigerator for the first time, please observe the following instructions during the initial six hours.
 - The door should not be opened frequently.
 - It must be operated empty without any food in it.
 - Do not unplug your refrigerator. If a power failure occurs out of your control, please see the warnings in the “Recommended solutions for the problems” section.
- i** Original packaging and foam materials should be kept for future transportations or moving.

5 Using your refrigerator

Indicator Panel

This touch-control indicator panel allows you to set the temperature without opening the door of your refrigerator. Just touch the relevant button with your finger to set the temperature.

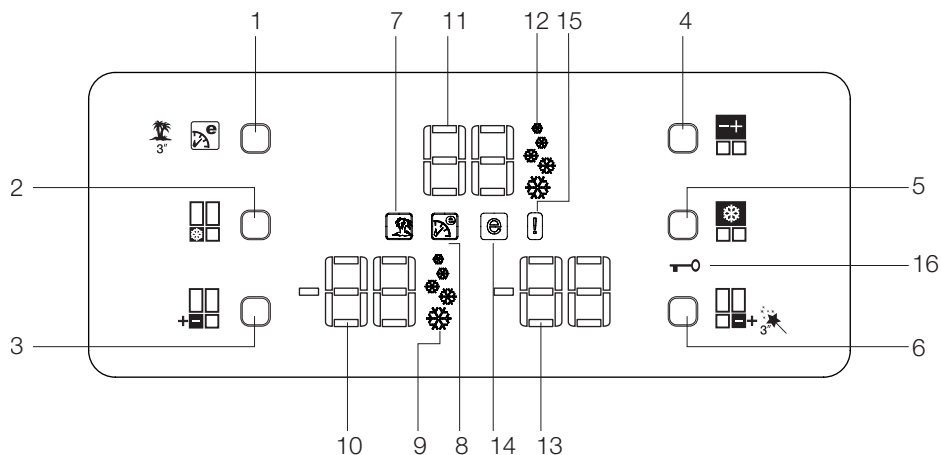

- | | |
|--|--|
| 1. Eco Extra/Vacation Button | 10. Freezer Compartment Temperature Indicator |
| 2. Fast Freeze Button | 11. Fridge Compartment Temperature Indicator |
| 3. Freezer Compartment Temperature Setting Button | 12. Quick Cool Function Indicator |
| 4. Fridge Compartment Temperature Setting Button | 13. Flexi Zone Storage Compartment Temperature Indicator |
| 5. Quick Cool Button | 14. Economy Mode Indicator |
| 6. Flexi Zone Storage Compartment Temperature Setting Button | 15. Error Status Indicator |
| 7. Vacation Function Indicator | 16. Key Lock Indicator |
| 8. Eco Extra Function Indicator | |
| 9. Quick Freeze Function Indicator | |

i Figures that take place in this instruction manual are schematic and may not correspond exactly with your product. If the subject parts are not included in the product you have purchased, then it is valid for other models.

1. Eco Extra/Vacation Button

Press this button briefly to activate the Eco Extra function. Press and hold this button for 3 sec. to activate the Vacation function. Press this button again to deactivate the selected function.

2. Fast Freeze Button

Press this button briefly to activate the Fast Freeze function. Press this button again to deactivate the selected function.

3. Freezer Compartment Temperature Setting Button

Press this button to set the temperature of the freezer compartment to -18, -20, -22, -24, -18... respectively. Press this button to set the desired temperature for the Freezer Compartment.

4. Fridge Compartment Temperature Setting Button

Press this button to set the temperature of the fridge compartment to 8, 6, 4, 2, 8... respectively. Press this button to set the desired temperature for the Fridge Compartment.

5. Quick Cool Button

Press this button briefly to activate the Quick Cool function. Press this button again to deactivate the selected function.

6. Flexi Zone Storage Compartment Temperature Setting Button

You can set the Flexi Zone Storage

Compartment either as a Freezer or a Cooler. Press and hold this button for 3 sec. to set the Flexi Zone Storage Compartment either as a Freezer or a Cooler. This compartment is set as a Freezer Compartment at factory.

If the Flexi Zone Storage Compartment is set as a Freezer, then the temperature of the Flexi Zone Storage Compartment will change as -18, -20, -22, -24, -18... respectively each time you press this button. If the Flexi Zone Storage Compartment is set as a Cooler, then the temperature of the Flexi Zone Storage Compartment will change as -6, 0, 2, 4, 6, 8, 10... respectively each time you press this button.

7. Vacation Function Indicator

Indicates that the vacation function is active. If this function is active, “- -“ appears on the indicator of the fridge compartment and no cooling is performed in the fridge compartment. Other compartments will be cooled in accordance with the temperature set for them.

Press the relevant button again to deactivate this function.

8. Eco Extra Function Indicator

Indicates that the Eco Extra function is active. If this function is active, your refrigerator will automatically detect the least usage periods and energy-efficient cooling will be performed during those times. Economy indicator will be active while energy-efficient cooling is performed.

Press the relevant button again to deactivate this function.

9. Quick Freeze Function Indicator

Indicates that the Quick Freezer function is active. Use this function when you place fresh food into the freezer compartment or when you need ice. When this function is active, your refrigerator will run for 6 hours without stopping.

Press the relevant button again to deactivate this function.

10. Freezer Compartment Temperature Indicator

Indicates the temperature set for Freezer Compartment.

11. Fridge Compartment Temperature Indicator

Indicates the temperature set for Fridge Compartment.

12. Quick Cool Function Indicator

Indicates that the Quick Cool function is active. Use this function when you place fresh food into the fridge compartment or when you need to cool your food quickly. When this function is active, your refrigerator will run for 2 hours without stopping.

Press the relevant button again to deactivate this function.

13. Flexi Zone Storage Compartment Temperature Indicator

Indicates the temperature set for Flexi Zone storage compartment.

14. Economy Mode Indicator

Indicates that the refrigerator is running in energy-efficient mode. Freezer Compartment temperature This indicator will be active if the function is set to -18 or the energy efficient cooling is being performed due to Eco-Extra function.

15. Error Status Indicator

If your refrigerator does not cool adequately or if there is a sensor failure, this indicator will be activated. When this indicator is active, Freezer Compartment Temperature indicator will display "E" and Fridge Compartment Temperature Indicator will display numbers such as "1,2,3...". These numbers on the indicator provides information about the error to the service personnel.

16. Key Lock Indicator

Use this function if you do not want your refrigerator temperature setting changed. Press Quick Cool Button and Flexi Zone Storage Compartment Temperature Setting Button simultaneously for 3 sec. to activate this feature.

Press the relevant buttons again to deactivate this function.

Door Open Alarm:

If the either of the fridge compartment door or **Flexi Zone** Storage Compartment door remains open for minimum 1 minutes, audio Door Open Alarm will be activated. Just press any button on the indicator or close the open door to silence the alarm.

Egg tray

- You can install the egg holder to the desired door or body shelf.
- Never store the egg holder in the freezer compartment.

Sliding Body Shelves

Sliding body shelves can be pulled by slightly lifting up from the front and moved back and forth. They come to a stop point when pulled towards front to allow you reach the foods placed at the back of the shelf; when it is pulled after slightly lifting upwards at the second stop point, the body shelf will be released.

The shelf should be held tightly from the bottom as well in order to prevent it from tipping over. The body shelf is placed on the rails at the sides of the refrigerator body by bringing it to one lower or one upper level.

The body shelf should be pushed backwards to seat it completely.

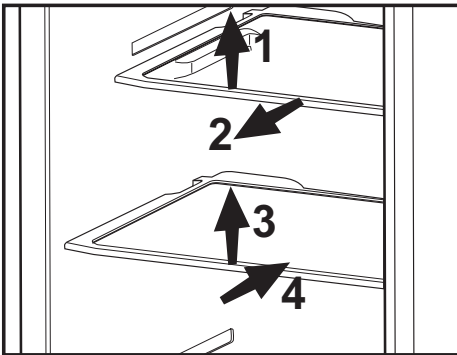

Crisper

Crisper of your refrigerator is designed specially to keep your vegetables freshly without losing their humidity. For this purpose, cool air circulation occurs around the crisper in general.

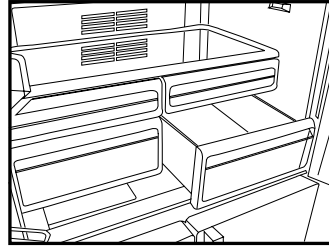

Chiller compartment

Chiller compartments enable the foods to be frozen become ready for freezing. You can also use these compartments to store your food at a temperature a few degrees below the fridge compartment.

You can increase the inner volume of your refrigerator by removing any of the chiller compartments. To do this, pull the compartment towards yourself; the compartment will lean against the stopper and stop. This compartment will be released when you lift it about 1 cm and pull it towards yourself.

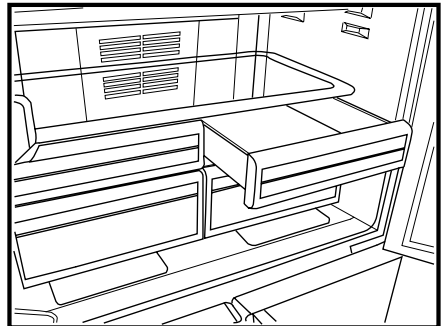

Rotating Middle Section

Rotating middle section is intended to prevent the cold air inside your refrigerator from escaping outside. Rotating middle section aids in sealing since the gaskets on the door presses on the surface of the Rotating middle section when the doors of the fridge compartment are closed. Another reason that your refrigerator is equipped with a rotating middle section is that it increases the net volume of the fridge compartment. Standard middle sections occupy some non-usable volume in the refrigerator.

The rotating middle section must be closed while the left door of the fridge compartment is open. It must not be opened manually, it is rotating by means of a plastic part mounted on the cabinet.

Multi Zone Storage Compartment

The Multi Zone Storage Compartment of your refrigerator may be used in any desired mode by adjusting it to fridge (2/4/6/8 °C) or freezer (-18/-20/-22/-24) temperatures. You can keep the compartment in the desired temperature with the Multi Zone Storage Compartment Temperature Setting Button. The temperature of the Multi Zone Storage Compartment may be set to 0 and 10 degrees in

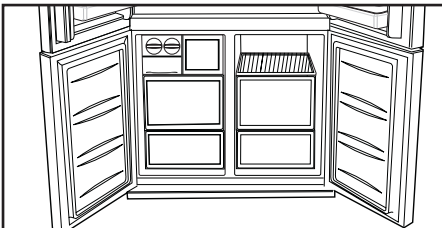

addition to the fridge compartment temperatures and to -6 degrees in addition to the freezer compartment temperatures. 0 degree is used to store the deli products longer, and -6 degrees is used to keep the meats up to 2 weeks in an easily cuttable condition.

i The feature of switching to a Fridge or Freezer compartment is provided by a cooling element located in the closed section (Compressor Compartment) behind the refrigerator. During operation of this element, sounds similar to the sound of seconds heard from an analog clock may be heard. This is normal and is not fault cause.

Blue light

Foodstuff stored in the crispers that are enlightened with a blue light continue their photosynthesis by means of the wavelength effect of blue light and thus, preserve their freshness and increase their vitamin content.

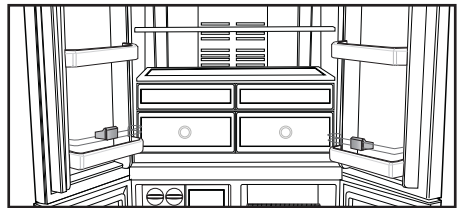

6 Maintenance and cleaning

- ⚠ Never use gasoline, benzene or similar substances for cleaning purposes.
- ⚠ We recommend that you unplug the appliance before cleaning.
- ⚠ Never use any sharp abrasive instrument, soap, household cleaner, detergent and wax polish for cleaning.
- ℹ Use lukewarm water to clean the cabinet of your refrigerator and wipe it dry.
- ℹ Use a damp cloth wrung out in a solution of one teaspoon of bicarbonate of soda to one pint of water to clean the interior and wipe it dry.
- ⚠ Make sure that no water enters the lamp housing and other electrical items.
- ⚠ If your refrigerator is not going to be used for a long period of time, unplug the power cable, remove all food, clean it and leave the door ajar.
- ℹ Check door seals regularly to ensure they are clean and free from food particles.
- ⚠ To remove door racks, remove all the contents and then simply push the door rack upwards from the base.

Protection of plastic surfaces

- ℹ Do not put the liquid oils or oil-cooked meals in your refrigerator in unsealed containers as they damage the plastic surfaces of your refrigerator. In case of spilling or smearing oil on the plastic surfaces, clean and rinse the relevant part of the surface at once with warm water.

7 Recommended solutions for the problems

Please review this list before calling the service. It might save you time and money. This list includes frequent complaints that are not arising from defective workmanship or material usage. Some of the features described here may not exist in your product.

The refrigerator does not operate.

- Is the refrigerator properly plugged in? Insert the plug to the wall socket.
- Is the fuse of the socket which your refrigerator is connected to or the main fuse blown out? Check the fuse.

Condensation on the side wall of the fridge compartment (MULTIZONE, COOL CONTROL and FLEXI ZONE).

- Very cold ambient conditions. Frequent opening and closing of the door. Highly humid ambient conditions. Storage of food containing liquid in open containers. Leaving the door ajar. Switching the thermostat to a colder degree.
- Decreasing the time the door left open or using it less frequently.
- Covering the food stored in open containers with a suitable material.
- Wipe the condensation using a dry cloth and check if it persists.

Compressor is not running

- Protective thermic of the compressor will blow out during sudden power failures or plug-out plug-ins as the refrigerant pressure in the cooling system of the refrigerator has not been balanced yet. Your refrigerator will start running approximately after 6 minutes. Please call the service if the refrigerator does not startup at the end of this period.
- The fridge is in defrost cycle. This is normal for a full-automatically defrosting refrigerator. Defrosting cycle occurs periodically.
- Your refrigerator is not plugged into the socket. Make sure that the plug is properly fit into the socket.
- Are the temperature adjustments correctly made?
- Power might be cut off.

The fridge is running frequently or for a long time.

- Your new product may be wider than the previous one. This is quite normal. Large refrigerators operate for a longer period of time.
- The ambient room temperature may be high. This is quite normal.
- The refrigerator might have been plugged in recently or might have been loaded with food. Cooling down of the refrigerator completely may last for a couple of hours longer.
- Large amounts of hot food might have been put in the refrigerator recently. Hot food causes longer running of the refrigerator until they reach the safe storage temperature.
- Doors might have been opened frequently or left ajar for a long time. The warm air that has entered into the refrigerator causes the refrigerator to run for longer periods. Open the doors less frequently.
- Freezer or fridge compartment door might have been left ajar. Check if the doors are tightly closed.
- The refrigerator is adjusted to a very low temperature. Adjust the refrigerator temperature to a warmer degree and wait until the temperature is achieved.
- Door seal of the fridge or freezer may be soiled, worn out, broken or not properly seated. Clean or replace the seal. Damaged/broken seal causes the refrigerator to run for a longer period of time in order to maintain the current temperature.

Freezer temperature is very low while the fridge temperature is sufficient.

- The freezer temperature is adjusted to a very low temperature. Adjust the freezer temperature to a warmer degree and check.

Fridge temperature is very low while the freezer temperature is sufficient.

- The fridge temperature might have been adjusted to a very low temperature. Adjust the fridge temperature to a warmer degree and check.

Food kept in the fridge compartment drawers are freezing.

- The fridge temperature might have been adjusted to a very low temperature. Adjust the fridge temperature to a warmer degree and check.

Temperature in the fridge or freezer is very high.

- The fridge temperature might have been adjusted to a very high degree. Fridge adjustment has an effect on the temperature of the freezer. Change the temperature of the fridge or freezer until the fridge or freezer temperature reaches to a sufficient level.
- Doors might have been opened frequently or left ajar for a long time; open them less frequently.
- Door might have been left ajar; close the door completely.
- Large amount of hot food might have been put in the refrigerator recently. Wait until the fridge or freezer reaches the desired temperature.
- The refrigerator might have been plugged in recently. Cooling down of the refrigerator completely takes time.

The operation noise increases when the refrigerator is running.

<ul style="list-style-type: none"> • The operating performance of the refrigerator may change due to the changes in the ambient temperature. It is normal and not a fault.
Vibrations or noise.
<ul style="list-style-type: none"> • The floor is not even or it is weak. The refrigerator rocks when moved slowly. Make sure that the floor is strong enough to carry the refrigerator, and level. • The noise may be caused by the items put onto the refrigerator. Items on top of the refrigerator should be removed.
There are noises coming from the refrigerator like liquid spilling or spraying.
<ul style="list-style-type: none"> • Liquid and gas flows happen in accordance with the operating principles of your refrigerator. It is normal and not a fault.
There is a noise like wind blowing.
<ul style="list-style-type: none"> • Fans are used in order to cool the refrigerator. It is normal and not a fault.
Condensation on the inner walls of refrigerator.
<ul style="list-style-type: none"> • Hot and humid weather increases icing and condensation. It is normal and not a fault. • Doors might have been left ajar; make sure that the doors are closed fully. • Doors might have been opened frequently or left ajar for a long time; open them less frequently.
Humidity occurs on the outside of the refrigerator or between the doors.
<ul style="list-style-type: none"> • There might be humidity in the air; this is quite normal in humid weather. When the humidity is less, condensation will disappear.
Bad odor inside the refrigerator.
<ul style="list-style-type: none"> • Inside of the refrigerator must be cleaned. Clean the inside of the refrigerator with a sponge, lukewarm water or carbonated water. • Some containers or package materials might cause the smell. Use a different container or different brand packaging material.
The door is not closing.
<ul style="list-style-type: none"> • Food packages may prevent the door's closing. Replace the packages that are obstructing the door. • The refrigerator is not completely upright on the floor and rocking when slightly moved. Adjust the elevation screws. • The floor is not level or strong. Make sure that the floor is level and capable to carry the refrigerator.
Crispers are stuck.
<ul style="list-style-type: none"> • The food might be touching the ceiling of the drawer. Rearrange food in the drawer.

8 Guarantee Details

GUARANTEE DETAILS

Your new Beko product is guaranteed against the cost of breakdown repair for twelve months from the date of the original purchase.

What is covered?

- Repairs necessary as a result of faulty materials, defective components or manufacturing defect.
- The cost of functional replacement parts, but excluding consumable items.
- The labour costs of a Beko approved repairer to carry out the repair.

What is not covered?

- Transit, delivery or accidental damage or misuse and abuse.
- Cabinet or appearance parts, including knobs, flaps, handles or container lids.
- Accessories or consumable items including but not limited to, ice trays, scrapers, cutlery baskets, filters and light bulbs.
- Repairs required as a result of unauthorised repair or inexperienced installation that fails to meet the requirements contained in the user instruction book.
- Repairs to products used on commercial or non-residential household premises.
- Loss of frozen food in freezers or fridge/freezers. (Food loss insurance is often included within your household contents insurance policy, or may be available separately from your retailer).

Important notes.

- Your Beko product is designed and built for domestic household use only.
- The guarantee will be void if the product is installed or used in commercial or non-residential domestic household premises.
- The product must be correctly installed, located and operated in accordance with the instructions contained in the User Instructions Booklet provided.
- Professional installation by a qualified Electrical Domestic Appliance Installer is recommended for all Washing Machines, Dishwashers and Electric Cookers
- Gas Cookers must only be installed by a Gas Safe (or BORD GAIS) registered Gas Installer.
- The guarantee is given only within the boundaries of the United Kingdom and the Republic of Ireland.
- The guarantee is applicable only to new products and is not transferable if the product is resold.
- Beko disclaims any liability for incidental or consequential damages.
The guarantee does not in anyway diminish your statutory or legal rights.

9 How To Obtain Service

HOW TO OBTAIN SERVICE

Please keep your purchase receipt or other proof of purchase in a safe place; you will need to have it should the product require attention under guarantee.

You should also complete the details below; it will help us assist you when requesting service. (The model number is printed on the Instruction Booklet and the serial number is printed on the Rating Label affixed to the appliance)

Model No: Serial No: Retailer: Date of purchase:

For service under guarantee simply telephone the appropriate number below

UK Mainland & Northern Ireland

Fridges & Freezers	0845 6004903
Electric Cookers	0845 6004902
Gas & Dual Fuel Cookers	0845 6004905
Washing Machines & Dishwashers	0845 6004906

Republic of Ireland

All Refrigeration, All Cookers Washing Machines & Dishwashers	01 862 3411
--	-------------

Before requesting service please check the trouble-shooting guide in the Operating Instructions as a charge may be levied where no fault is found even though your product may still be under guarantee.

Service once the manufacturers guarantee has expired.

If you have purchased an extended guarantee please refer to the instructions contained within the extended guarantee agreement document. Otherwise please call the appropriate number above where service can be obtained at a charge.

Should you experience any difficulty in obtaining service please contact the Beko Customer Help-Line. Tel: 0845 6004911 e-mail: service@beko.co.uk

BEKO



BEKO plc
Beko House
Caxton Way
Watford
Hertfordshire
WD18 8UF
Tel: 0845 6004911
Fax: 0845 6004922
e-mail: service@beko.co.uk
website: www.beko.co.uk

Printed in Turkey

Part no: 57 1025 0000
Revision no: AA